

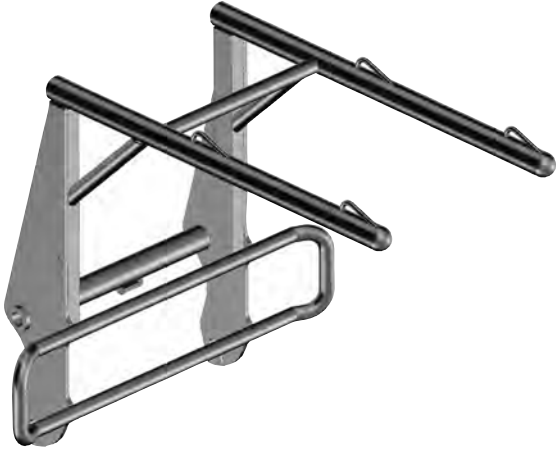

BIG BAG HANDLER



- Increases the efficiency & safety of all big-bag handling operations.
- Tubular structure- limits the risk of bag damages & fall.
- Handles indifferently big bags with 1, 2 or 4 loops (600kg/ loop).
- 100% designed & homologated as a suspended load attachment.



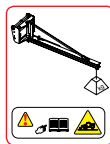

Anti-swing bag stabilizer-
increases stability



4 non-damaging bag stops-
improved safety

	HBB 1500 / 2400
Hook capacity (kg)	2400
Forward reach / depth (mm)	1570
Weight (kg)	186

Machine compatibility	
Reference	931627
MLT 625	x
MLT 630 <i>NewAg</i>	x
MLT 635 <i>NewAg</i>	x
MLT-X 732	x
MLT 733 <i>NewAg</i>	x
MLT-X 735	x
MLT 737 <i>NewAg</i>	x
MLT 741 <i>NewAg</i>	x
MLT-X 741	x
MLT 840	x
MLT 940 <i>NewAg</i>	x
MLT 845	x
MLT 1040	x
MT 625	x
MT 732	x
MT 835	x
MT 932	x
MT 1030	x
MT 1135	x
MT 1335	x
MT 1435 €3B	x
MT 1440	x
MT 1840	x
MRT 3255	x

MANDATORY MACHINE EQUIPMENT: ✕